

[413] LAYING OF GTI SEALING TILES SUBJECT TO TECHNICAL REPORT

Tiles are all laid in the same direction.



Min. ambient temperature: 10 °C



Laying on extra-long double sided adhesive every 500m²



Min. surface temperature: 10 °C

Before laying the floor covering, it should be inspected, so as to detect any visual defects.
In the event of any visual defects, please notify GERFLOR and do not start laying the product before receiving GERFLOR's approval.

If laying GTI tiles in supermarkets, refer to the specific Laying Principle.

1. AREAS OF APPLICATION

1.1- LAYING TYPE

FOREWORD: CONDITIONS FOR USE

	P RATING FOR NEW AND REFURBISHED PREMISES		LAYING METHOD WITH TEMPERATURE CONDITIONS	PERIPHERAL EXPANSION
GTI	U4P4S	P4 premises, also capable of withstanding large stationary or moving loads. Floor care is limited to the use of a self-propelled floor scrubbing machine.	Since the stores are air-conditioned, the floor covering is not subject to temperature deviations greater than 20 °C. The dimensional stability of GTI / GTI Max tiles enables loose laying subject to a 500m ² limit.	Due to the year-round heat regulation in the buildings, Gerflor recommends allowing for a 0.5 cm peripheral clearance.

DYNAMIC LOAD RESISTANCE			
Traffic frequency and type	Load according to tyre or wheel type		
	Polyurethane or equivalent hardness	"Solid rubber or pneumatic tyre. This type of machine should not be left on the tiles when idle, so as to prevent dye migration. It should only be used for restocking shelves."	
GTI Routine frequency, typically store stocking and cleaning	Total load per wheel		Electrically or thermally powered handling machinery is liable to give rise to heating-related damage due to wheel skidding. It is advisable to ensure that equipment is suitable for the floor covering structure (e.g.: machinery equipped with an anti-skid system) Paired wheels are counted as a single wheel when the distance between them (centre distance or track) is < 20 cm. Metal wheels are excluded.
	< 1,000 kg	< 2,000 kg	
	Contact pressure		
	< 60 kg	Not applicable	
	Total loaded weight		
	< 3,000 kg	< 6,000 kg	
	Speed		
	< 10 km/h		
Handling			
Stacker, nominal capacity 1,600 kg		Fork-lift truck, nominal capacity 2,000 kg - Car	
Cleaning			
Self-propelled automatic scrubbing machine with on-board operator			

LAYING OF GTI SEALING TILES SUBJECT TO TECHNICAL REPORT

	STATIC LOAD RESISTANCE		
	MAXIMUM LOAD PRESSURE	HANDLING MACHINERY EQUIVALENCE	
GTI	< 50 kg / cm ²	< 1,000 kg / Wheel or per support	Due the broad selection of handling machinery, consoles and floor scrubbing machines, it is necessary to account for the various factors listed opposite. For this reason, it is important to know the geometry of the console legs, the wheel type and configuration (single or double), the hardness values and the handling method (with or without on-board operator, speed, acceleration and braking mode)

1.2 - TYPE OF PREMISES AND USE

This floor covering is particularly suitable for areas subject to heavy traffic in clean rooms, and production, storage and handling areas. It is not suitable for wet areas (showers, etc.). It should be applied in temperature-regulated premises (store, retail area, etc.).

1.3 - SURFACES

1.3.1. Preparatory work for new flooring

MECHANICAL PREPARATION: The surfaces should be prepared with care so as to remove any soiling, laitance, treatment products or any other foreign bodies.

BUMP AND DEPRESSION TREATMENT: Sanding of bumps.
Cleaning: using industrial vacuum cleaner
Point levelling of depressions with P4S or P4SR floor sealer

CRACK TREATMENT:

On any surface, cracks should be detected beforehand. They are not treated, if they are flush, and if they are < 3 mm wide.

JOINT TREATMENT:

Contraction joint: If they have an opening < 4 mm, they are not treated.
Expansion joint: Following thorough cleaning, expansion joints are preserved: end profiles with or without an overlay are arranged on either side of the joint.
Construction joint: Similar to cracks, if they have an opening < 3 mm, they are not treated.

LOCALISED LEVELLING:

Surface levelling may be required, particularly where the surface is not sufficiently even or in poor condition.

Required characteristics on dry surface (moisture content ≤ 4.5%):

The sealer performances should meet P4S or P4SR rating specifications.

Required characteristics on wet surface (moisture content between 4.5 and 7%): We recommend the use of outdoor floor sealers (consult sealer manufacturers):

1.3.2 - Refurbished surfaces - List of surfaces

	RESIN		ADHESIVE-BONDED TILING, SEALED TILING		CARPET
	Surface evenness < 7 mm / 2 m	Surface evenness > 7 mm / 2 m	Surface evenness < 7 mm / 2 m	Surface evenness > 7 mm / 2 m	
Retention of existing floor covering % damaged surface < 10 %	direct laying	sanded epoxy resin grout to restore surface evenness	direct laying with joint treatment in the case of pronounced joints	treatment of tiling with primer and dressing sealer	removal
Removal of existing floor covering % damaged surface area > 10%	direct laying on stripped surface	removal see new concrete + concrete treatment for surface evenness	direct laying on stripped surface	removal see new concrete + concrete treatment for surface evenness	

Laying on bituminous coatings can be envisaged if the surface evenness is < 10 mm under the 2 m rule. Beyond this, bumps need to be planed using suitable means. We do not recommend the use of shrink-free resin.

1.4 - UNDER-FLOOR HEATING

Laying on radiant under-floor heating (UFH) systems is authorised on surfaces with a surface evenness < 7 mm / 2 m. However, in this case, the tiles must be completely bonded on the entire surface.
Laying on conventional under-floor storage heating is possible (see section 5.4 of the NF P 62-203-1 (DTU 53.2) standard). However, in this case, the tiles must be completely bonded on the entire surface.

BUILDING FLOOR COVERINGS

LAYING OF GTI SEALING TILES SUBJECT TO TECHNICAL REPORT

2. LAYING

■ 2.1 - STORAGE & WORK CONDITIONS

Before laying the floor covering, it should be inspected, so as to detect any visual defects. In the event of any visual defects, please notify GERFLOR and do not start laying the product before receiving GERFLOR's approval.

Since the stores are air-conditioned, these tiles are not subject to temperature deviations greater than 20 °C. The tiles should be stored on-site for 24 to 48 hours beforehand at ambient temperature.

⚠ DO NOT MIX BATCHES

■ 2.2- LAYING TYPE

Attraction® / GTI / GTI Max tiles can be bonded as per DTU 53.2, but they are essentially intended for loose (non-adhesive) laying, in single pieces limited to 500 m². For larger surface areas, the surface is split into 500 m² sections and the joints between areas are sealed with adhesive.

■ 2.3 -DETAILED LAYING

2.3.1 Extra-wide double-sided adhesive positioning

Splitting of surfaces into 500 m² sections

Since loose laying is limited to 500 m², it is necessary to envisage splitting into 500 m² sections by previously applying an extra-wide double-sided adhesive.

Regardless of the configuration, double-sided adhesive should be applied, never exceeding more than **20 rows** of tiles.

Study the layout so as to prevent the position of the double-sided adhesive and the seam between each area from being situated in the main aisles to avoid heavy traffic.

• Example of configuration < 500 m² (clothing, cosmetics aisles, etc.),

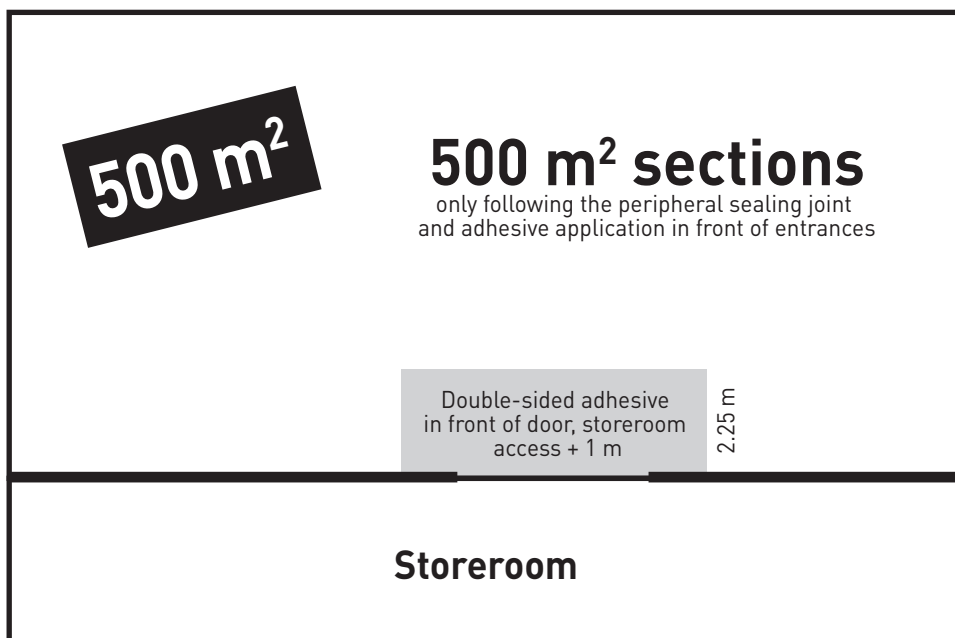

Each 500m² section may include turning or liquid areas, storeroom entrances, also requiring double-sided adhesive application.
Avoid locating 500 m² demarcation areas in a main aisle.

LAYING OF GTI SEALING TILES SUBJECT TO TECHNICAL REPORT

2.3.2 Double-sided adhesive application

• Note on surface:

The surface should be dry, hard, perfectly adherent, load-bearing, plane and free from grease, dust and silicone.

Bay windows: In front of bay windows, apply double-sided adhesive.

• If applying primer:

- Apply evenly on the surface at a consumption rate of 70 to not more than 100 g/m², with a foam roller, in crisscross strokes.
- Avoid any splash/drip/streak formation.



- Leave to dry for at least 2 hours, with the room well-ventilated. UZIN Planus or Epoxy PE 480 primer should be perfectly dry. The drying time depends on the surface, weather conditions and ventilation. Tiles should not rest on the Primer.

• Dry adhesive application:

- Unroll the double-sided adhesive, pressing lightly on the adhesive with a gluing block

Important: The strongly adhesive (protected) side must never rest on the surface!



- Only unroll the amount of double-sided adhesive that can be covered that day with the floor covering.
- Roll up the remaining with the protective paper (to protect the surface and the section from dust).

• Laying PVC tiles on adhesive:

- Mark the lines on the protective paper either with a chalk line or a pencil.
- Mark the starting point of the first tiles and the first row of tiles.
- Place a steel rule along the line and cut only the protective paper with a straight blade.
- Remove the protective paper from the double-sided adhesive, pulling straight and flat. The line created forms the starting line of the first tiles of the first row.
- Lay the tiles and interlock them.
- Stack the protective papers as you progress and then roll them up (minimises waste volume).
- Remove the protective paper as you progress, pulling straight and flat.
- If laying is discontinued, the protective paper may be put back in place to protect the double-sided adhesive.
- After laying, apply adhesive generously/apply a pasting roll, in crisscross strokes on the entire surface.

• Removing tiles and double-sided tape adhesive:

Double-sided adhesive allows you to remove the floor covering without leaving any trace of adhesive and without damaging the surface.

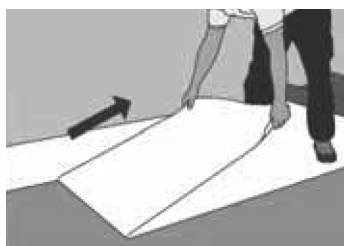

- Disengage the tiles.
- Starting in one corner, detach the double-sided adhesive from the surface.
- Remove the floor covering and double-sided adhesive by pulling at ground level.

2.3.3 Installation of GTI tiles

• Precautions

The tiles are delivered on a pallet. It is imperative not to mix the different batches.

Direction of installation: The tiles are laid ALL in the same direction.

Observe the direction indicated by the arrow on the back of the slab. Pressed materials, such as GTI tiles, may have dimensional tolerances from one series to another or from one color to another which may vary by 1mm.

In this case, the tiles can:

- Either not be able to fit
- In this case, plan to cut the dovetails and weld the slabs with a double-sided adhesive 5 cm wide on each side of the weld
- Easy to fit together

In this case, you must also place a double sided adhesive 5 cm wide on both sides to avoid any risk of unclipping over time.

• Implementation

The use of slabs on large surfaces must always be done by working on the two axes that have been drawn beforehand, either along a wall or between two zones of 500m² (see drawing) or crosses in the middle of the room.

- General case
Start crosswise in the middle of the room.
Install the stair tiles ¼ by ¼ of the room.

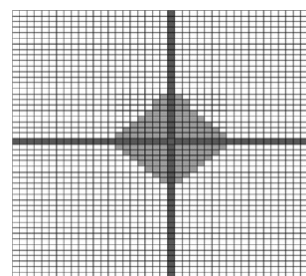

- Implantation along a wall
Start in the middle of the implantation.
Install the stair tiles on both sides.

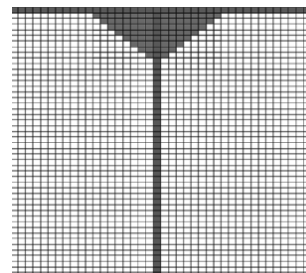

BUILDING FLOOR COVERINGS

LAYING OF GTI SEALING TILES SUBJECT TO TECHNICAL REPORT

- Lay in steps for easier tile interlocking and to prevent displacement. The tiles are laid in step and **ALL** in the same direction (see arrows on back of tiles).

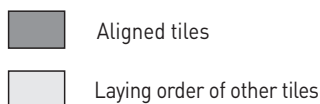
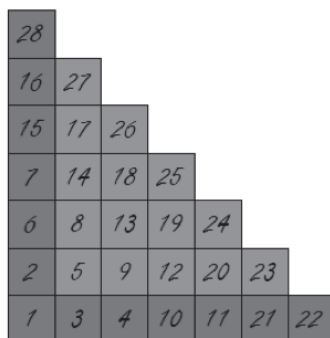

• Interlocking of tiles (procedure, tools, etc.), adjustment

- The tiles are interlocked by striking with a synthetic mallet or a non-rebound mallet and a wooden block.
- The tiles are interlocked from the corner to the edge.

Tools required: Cutter - Tape measure - Metal rule - Metal tracing wheel - Wooden or synthetic resin mallet



Non-rebound mallet

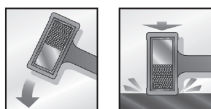

	JANSER	ROMUS	WOLFF
Non-rebound mallet	Referencing in progress	94964	Referencing in progress

• Peripheral levelling

The tiles should be positioned such that the peripheral cuts are $> \frac{1}{2}$ tile

Cutting (procedure, tools, etc.)

- Peripheral clearance: in standard sections, the peripheral clearance is 0.5 cm.
- Provide a circular saw with platform for the duration of the work.
- Cutting is performed either with a cutter (1 pass on the surface and repeat on back), or using the transfer technique (scribing)
Scribing: Method for tracing or cutting parallel lines. For this, a marking gauge or a tile gauge is used.
- Position the tile to be cut on the last full tile laid.
- Take a full tile which will serve as a gauge.
- Lay it on the tile to be cut, pressing on the partition (wall). Leave a clearance of 0.5 cm.
- Mark the tile to be cut along the edge of the gauge, with a cutter equipped with a straight blade.
- Cut the part of the tile to be laid neatly and put it in place.

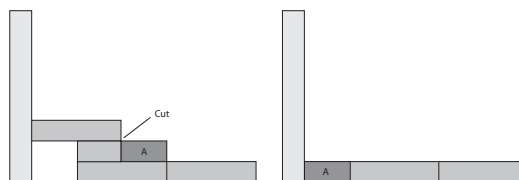

- For difficult areas (door frame, etc.), use demultiplied shears.



Mitre shears

Reference: Romus: 93415 / Janser: 237 530 000
For cutting around door frame bases, areas which are difficult to access.

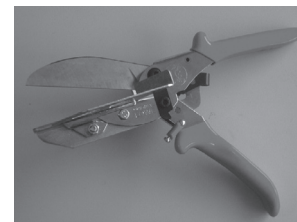

Demultiplied mitre shears

Reference: Janser: 262 284 000
For cutting around door frame bases, areas which are difficult to access.

3. HANDLING SPECIAL SECTIONS

■ 3.1 - SKIRTING

VYNAFLEX skirting or Gerflor Flexible skirting for finishing between floor and wall.

■ 3.2 - SURFACE EXPANSION JOINTS

- Flush joints: The RM 20-5 profile with PVC strips supplied by COUVRANEUF covers the joint. Adhesive-free tiles are cut along the joint and should be sealed onto the flexible joint.
- Joints with overlay profile: The profile is fitted over the floor covering and is secured on one side only.

■ 3.3 - DOOR PASSAGES AND STOPS

Use the following profiles according to the conditions of use: intensity of traffic, humidity level, etc.

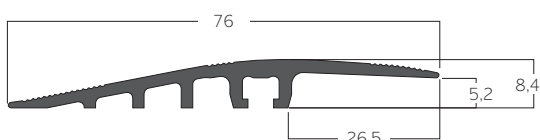

Finishing profile 0505

3 metre long profile strip with 9 pre-drilled countersunk holes, 4.3mm diameter.

- The spacing between holes is 313 mm
- The first hole is 90 mm from the end
- The holes are de-burred after drilling

LAYING OF GTI SEALING TILES SUBJECT TO TECHNICAL REPORT

4 x 50 mm TFZ screws and 6 x 30 mm

TFZ 4mm diameter screw,
50 mm long



6mm diameter plug,
30 mm long



GTI ACCESS and CORNER

3.3.1 - GTI ACCESS 635 X 320 mm

3.3.2 - GTI CORNER 320 mm x 320 mm

These accessories need to be glued with two-component and weighted during the setting of the adhesive (6-12 hours).

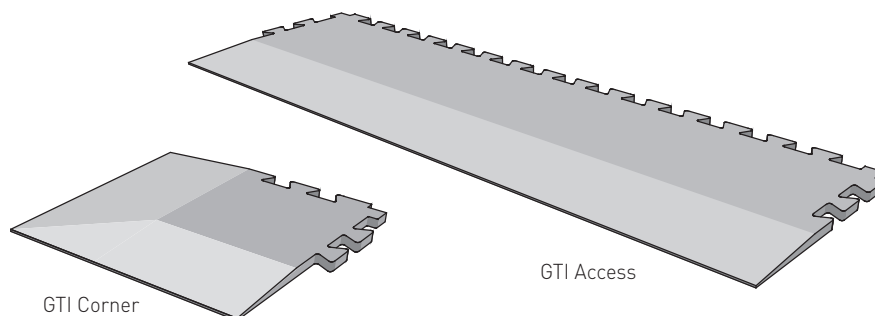

3.4 - CUTTING AROUND DOOR FRAME BASES AND SPECIAL SECTIONS



For cutting around door frame bases, areas which are difficult to access
Available from Gerflor



Demultiplied mitre shears
Reference: Janser: 262 284 000

For cutting around door frame bases, areas which are difficult to access

Mitre shears

Reference: Romus: 93415 /
Janser: 237 530 000

3.5 - SEALANT APPLICATION IN PERIPHERAL CLEARANCE

We recommend applying a polyurethane or hybrid sealant (M.S. Polymer) in the peripheral clearance to prevent any water or other penetration.

Peripheral clearance, profile overlay.

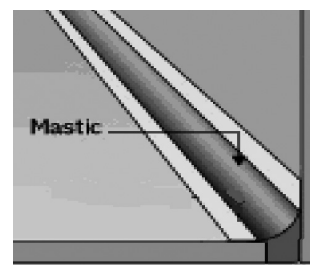

4. PUTTING FIXTURES BACK IN PLACE

- Consoles (whether stocked or not) and other display units should be put back in place before the distribution plates to prevent slippage of the loose laid material.
- Any damage to the material caused by putting fixtures back into place shall not be accepted by the installer or material manufacturer.

5. REPAIRS AND MAINTENANCE

5.1. - MONITORING, MAINTENANCE AND REPAIRS

The user should regularly monitor that the structure appears to be securely in place and notify the client and/or original installer of any anomalies that the user deems to incur potential risks in respect of the durability of the structure.

The technical analysis, requested by the user from the other parties, should differentiate between ageing due to normal wear and tear due to the traffic and use of the premises and accidental damage. If the observations made by the user are found to be justified following the technical analysis, the installer shall conduct the repair work within the scope of its contractual and/or legal commitments.

NOTE:

As part of this monitoring, the user should report any accidents linked with the operation of the premises without delay for repairs, in particular: cuts due to falling sharp objects, individual burns, etc. This maintenance may be carried out by the user's maintenance department.

5.2. - REPLACING ATTRACTION® / GTI TILES

- Replacing an adhesive-free tile
 - Cut a corner of the damaged tile
 - Disengage the dovetails
 - Fit a new tile in place, observing the laying direction.
- Replacing an adhesive-bonded tile
 - Cut a corner of the damaged tile
 - Disengage the dovetails
 - Cut and replace the adhesive
 - Fit a new tile in place, observing the laying direction.

